

2-Phase Hybrid Stepper Motor

ZSS Precision Stepper Motors

The proven series of ZSS two-phase hybrid stepper motors come into operation in many different application ranges: mechanical engineering, positioning and handling, food and packaging, etc.

The holding torques amount from 3.8 to 700 mNm.

The ZSS stepper motor's standard number of steps/rev. is 200, depending on the motor size 8, 24, 56, 72 or 500 steps/rev. are available.

When installed appropriately and wired correctly, the ZSS stepper motors contribute to fulfill the EMC requirements of the entire system.

Overview: Extensions

- **Stepper motor**
- **Geared stepper motor**
 - GPL low-backlash planetary gears
 - PLG planetary gears ¹⁾
 - HD Harmonic Drive gears ¹⁾
 - GSR worm gears ¹⁾
- **Stepper motor with motor brake ¹⁾**
Permanent magnet brake for 24V_{DC} supply voltage
- **Stepper motor with encoder ¹⁾**
Standard resolution 500 lines
3-channel optical incremental encoder

¹⁾ Separate data sheets being prepared.



Types / Mechanical Characteristics

Size	Type	2) Number of steps					3) 4) Standard windings	3) Holding torque mNm	Detent torque mNm	Rotor mass inertia 10 ⁻⁴ kg m ²	Permissible bearing load		Weight kg	Electrical connection		
		8	24	56	72	200					500	axial		radial	Free wire ends	Protective cover
		A									N	N		kg		
19	ZSS 19	<input type="checkbox"/>			<input checked="" type="checkbox"/>	<input checked="" type="checkbox"/>	0.3 / 0.6 / 1.2	3.8	0.9	0.0009	3	3	0.04	<input checked="" type="checkbox"/>	<input type="checkbox"/>	
	ZSS 20					<input checked="" type="checkbox"/>	0.3 / 0.6 / 1.2	5	1	0.0016	3	3	0.065	<input checked="" type="checkbox"/>	<input type="checkbox"/>	
25	ZSS 25	<input type="checkbox"/>	<input type="checkbox"/>		<input checked="" type="checkbox"/>	<input checked="" type="checkbox"/>	0.3 / 0.6 / 1.2	13	2	0.0025	5	5	0.07	<input checked="" type="checkbox"/>	<input type="checkbox"/>	
	ZSS 26					<input checked="" type="checkbox"/>	0.3 / 0.6 / 1.2	25	2.2	0.006	5	5	0.11	<input checked="" type="checkbox"/>	<input type="checkbox"/>	
32	ZSS 32				<input checked="" type="checkbox"/>	<input checked="" type="checkbox"/>	0.6 / 1.2 / 2.5	50	3	0.01	5	15	0.15	<input checked="" type="checkbox"/>	<input type="checkbox"/>	
	ZSS 33				<input type="checkbox"/>	<input checked="" type="checkbox"/>	0.6 / 1.2 / 2.5	75	3.3	0.018	5	15	0.23	<input checked="" type="checkbox"/>	<input type="checkbox"/>	
42	ZSS 41					<input checked="" type="checkbox"/>	0.6 / 1.2 / 2.5	100	4	0.025	20	40	0.26	<input type="checkbox"/>	<input checked="" type="checkbox"/>	
	ZSS 41/1					<input checked="" type="checkbox"/>	0.6 / 1.2 / 2.5	100	4	0.025	20	40	0.26	<input type="checkbox"/>	<input checked="" type="checkbox"/>	
	ZSS 42				<input type="checkbox"/>	<input checked="" type="checkbox"/>	0.6 / 1.2 / 2.5	140	5	0.045	20	40	0.32	<input type="checkbox"/>	<input checked="" type="checkbox"/>	
	ZSS 42/1				<input type="checkbox"/>	<input checked="" type="checkbox"/>	0.6 / 1.2 / 2.5	140	5	0.045	20	40	0.32	<input type="checkbox"/>	<input checked="" type="checkbox"/>	
	ZSS 43					<input checked="" type="checkbox"/>	0.6 / 1.2 / 2.5	260	7	0.077	20	40	0.47	<input type="checkbox"/>	<input checked="" type="checkbox"/>	
	ZSS 43/1					<input checked="" type="checkbox"/>	0.6 / 1.2 / 2.5	260	7	0.077	20	40	0.47	<input type="checkbox"/>	<input checked="" type="checkbox"/>	
52	ZSS 52			<input type="checkbox"/>	<input checked="" type="checkbox"/>	<input checked="" type="checkbox"/>	1.2 / 2.5	450	13	0.15	25	70	0.65	<input type="checkbox"/>	<input checked="" type="checkbox"/>	
56	ZSS 56					<input checked="" type="checkbox"/>	1.2 / 2.5	500	30	0.17	40	80	0.7	<input type="checkbox"/>	<input checked="" type="checkbox"/>	
	ZSS 57					<input checked="" type="checkbox"/>	1.2 / 2.5	700	50	0.24	40	80	0.9	<input type="checkbox"/>	<input checked="" type="checkbox"/>	

²⁾ ZSS 41/1, 42/1, 43/1, 52, 56, 57: Terminal plate with earthing screw
³⁾ Bipolar mode
⁴⁾ red = popular types

standard optional

Technical Information

- 2-phase hybrid stepper motors
- Standard number of steps 200 / step angle 1,8°
- Special numbers of steps depending on the motor size: 8, 24, 56, 72 or 500
- Standard type: 8-leads
 - Wiring as 4-lead stepper motor for bipolar control mode with parallel or in series connected windings
 - Wiring as 5- or 6-lead stepper motor for unipolar control mode
- Holding torques from 3.8 to 700 mNm
- Protection mode
 - IP 40 for ZSS with free wire ends
 - IP 50 for ZSS with protective cover
- Permiss. surface temperature -20 to +120 °C
- Design voltage
 - 42 V for ZSS 19 – 33, 41, 42, 43
 - 100 V für ZSS 41/1, 42/1, 43/1, 52 – 57 (with earthing screw)
- Insulation class F acc. to VDE 0530
- Test voltage
 - ZSS 19 – 52: 700 V (1 min)
 - ZSS 56 – 57: 1500 V (1 min)
- Optional:
 - 2nd shaft (IP 40)
 - 4-, 5- or 6-lead stepper motor wiring
- On request:
 - Cable output radial or flange side
 - Customized shaft design
 - Special windings

ZSS 19 to 33 Stepper Motors with Free Wire Ends

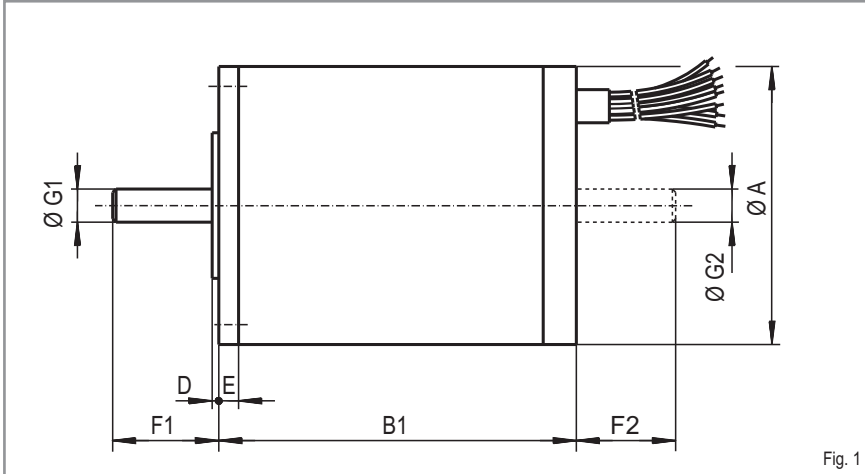

ZSS Designs



ZSS 41 to 57 Stepper Motors with Protective Cover

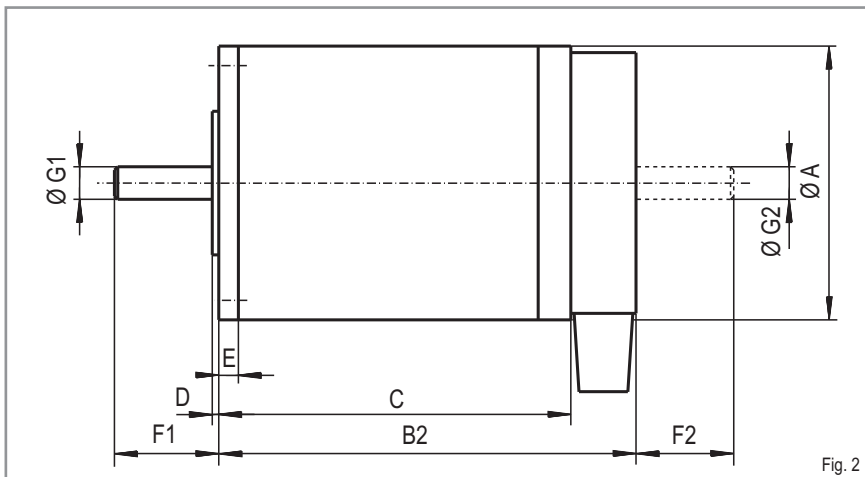

ZSS Standard Motor Flange

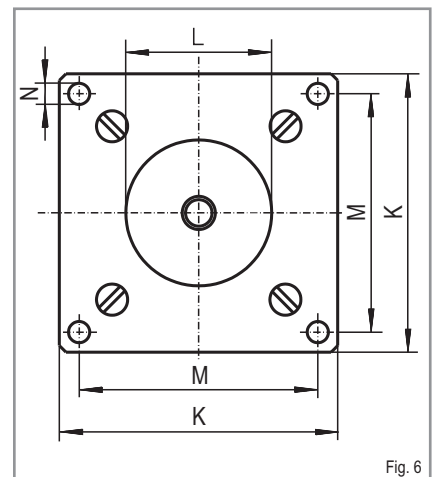

K1 Heat Sink for ZSS 19 to 57

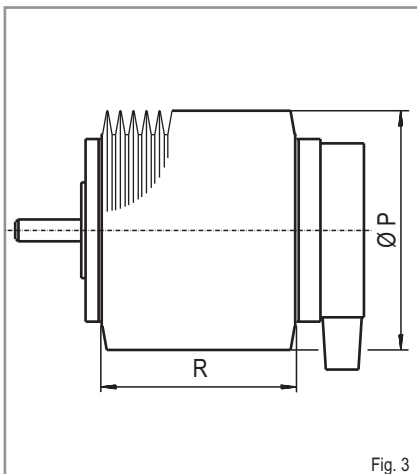

K2 Heat Sink for ZSS 19 to 57

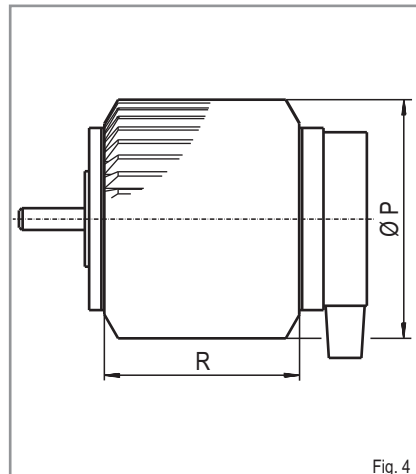

Optional Heat Sink

The ZSS stepper motors are also available with a mounted heat sink.

Depending on the motor's mounting position, a heat sink with radial fins (K1) or axial fins (K2) can be selected.

The use of a K1 heat sink increases the stepper motor's thermal dissipation surface by a factor of approx. 3.9.

With a K2 heat sink, it is increased by a factor of approx. 3.4.

A heat sink can be mounted subsequently, preferable by phytron.

Dimensions Stepper Motor / Heat Sink

Size	Type	Dimensions in mm															
		A	B1	B2	C	D	E	F1	F2	G1 ¹⁾	G2 ¹⁾	K	L _{g6}	M	N	P	R
19	ZSS 19	19	26.5			1	2	7.5	6.5	2.5	2.5	19	10	16	M2.5	26	20.5
	ZSS 20	19	43			1	2	7.5	6.5	2.5	2.5	19	10	16	M2.5	26	37
25	ZSS 25	25	31			1	2.5	9.5	8.5	3	3	25	14	21.5	2.2	35	24
	ZSS 26	25	47			1	2.5	9.5	8.5	3	3	25	14	21.5	2.2	35	40
32	ZSS 32	32	38.5			1	3	11	10	4	4	32	18	27	2.8	42	30
	ZSS 33	32	57.5			1	3	11	10	4	4	32	18	27	2.8	42	49
42	ZSS 41	42		49	39	1	3	16	15	5	4	42	22	36	3.2	55	30
	ZSS 41/1	42		49	39	1	3	16	15	5	4	42	22	36	3.2	55	30
	ZSS 42	42		64	54	1	3	16	15	5	4	42	22	36	3.2	55	45
	ZSS 42/1	42		64	54	1	3	16	15	5	4	42	22	36	3.2	55	45
	ZSS 43	42		79	69	1	3	16	15	5	4	42	22	36	3.2	55	60
	ZSS 43/1	42		79	69	1	3	16	15	5	4	42	22	36	3.2	55	60
52	ZSS 52	52		77	65	1.5	3.5	17.5	16	6	4	52	28	44	4.3	65	58
56	ZSS 56	56.4		69.1	57.1	1.5	4.5	22	20.5	6.35	6.35	60	38.1	47.15	5.2	78	44
	ZSS 57	56.4		85.1	73.1	1.5	4.5	22	20.5	6.35	6.35	60	38.1	47.15	5.2	78	60

¹⁾ Shaft diameter tolerances: ZSS 19 to 26: -0.005 to -0.009, from ZSS 32: g5

Leads / Cables

Motors with free wire ends

- ZSS 19 to 26
8 x AWG 28, free wire ends 300 mm
- ZSS 32/33
8 x AWG 26, free wire ends 300 mm

Motors with protective cover

- ZSS 41 to 43, ZSS 41/1 to 43/1
Cable outlet diameter max. 4.5 mm
- ZSS 52 to 57
Cable outlet diameter max. 5 mm

Optional Motor Brake

For vertical positioning units, ZSS 32 to 57 stepper motors with built-in 24 V_{DC} permanent magnet motor brake are optionally available.

- ZSS 32 to 43: KEB 01
Power 8 W / Nominal torque 0.4 Nm
Electrical connection: free wire ends
- ZSS 52 to 57: KEB 02
Power 10 W
Nominal torque 1 Nm
Electrical connection: circular connector

See data sheet: ZSS Stepper Motor with KEB Permanent Magnet Motor Brake (being prepared).

Optional Encoder

The ZSS 25 – 57 stepper motors with built-in incremental encoders are specially adapted for applications with variable speed drives or system monitoring.

- Motor connection with free wire ends
- Encoder connection with flat cable with 12-point connector
- Protection mode IP 20

See data sheet: ZSS Stepper Motor with HEDL 5540 Incremental Encoder (being prepared).

Stepper Motor with GPL Low-backlash Planetary Gear

ZSS Stepper Motor with GPL Gear

- Stepper motor mounted gear
- 1- to 3-stage planetary gear
- Low gear backlash
 - Standard: 20 to 50 arcmin
 - Low-backlash: 6 to 15 arcmin
- Maximum permanent torque 0.1 to 38 Nm
- 100% permissible short-term overload
- Adapted for permanent, alternate or intermittent operation
- Ideal for combinations with toothed belt modules
- 4:1 to 256:1 reduction ratios (depending on the gear type)
- High efficiency
- Low gear inertia
- Permissible temperature range –30 to +90 °C
- Maintenance-free permanent lubrication

Gear Material

- Gear housing
 - GPL 22: stainless steel
 - GPL 26 to 52: rustproof for normal environmental conditions
- Output shaft: 2 deep groove ball bearings

Gear Operating Modes

S1: Continuous operation

The gear box's operating time exceeds 15 minutes without a break or the duty cycle is more than 60%. In no case the gear box housing temperature may exceed 70 °C.

S5: Cyclical operation

The gear box's duty cycle is less than 60%. The number of operations per hour can range anywhere from a few to several thousand.

If the number of operations exceeds 1000 per hour, the maximum torque occurring has to be multiplied by a shock factor (fig. 9) to take into account the additional dynamic load.

The data in this publication are based on software models and empirical values and on a shock factor of 1.25.

Mechanical Characteristics

Gear	Stepper motor	Mechanical gear characteristics											
		Stages	Reduction ratios		Standard			Low-backlash			Torsional stiffness	Average mass inertia at output	Efficiency ¹⁾
					No-load backlash	Nominal torque S1	Emergency stop tor.	No-load backlash	Nominal torque S5	Emergency stop tor.			
					Nm			Nm					
GPL 22	ZSS 19 ZSS 20 ZSS 25 ZSS 26	1	4:1 5:1	7:1	20'	0.1	0.2	–	–	–	0.19	0.008	96
		2	16:1 20:1 28:1	35:1 49:1	35'	0.5	1	–	–	–	0.21	0.006	90
		3	64:1 80:1 112:1	140:1 196:1 245:1	50'	1.5	3	–	–	–	0.2	0.004	85
		1	3.5:1 4.33:1	6:1 7.67:1	20'	0.3	0.6	–	–	–	0.24	0.012	96
GPL 26	ZSS 25 ZSS 26	2	12.25:1 18.78:1 26:1	33.22:1 46:1	35'	1	2	–	–	–	0.26	0.010	90
		3	81.37:1 112.67:1 143.96:1	199.33:1 276:1	50'	3	6	–	–	–	0.25	0.0095	85
		1	4:1 4.5:1 5.2:1	6.25:1 8:1	20'	0.4	0.8	6'	0.8	1.6	0.3	0.015	96
GPL 32	ZSS 32 ZSS 33	2	16:1 18:1 20.8:1 25:1 29:1	32:1 36:1 41.6:1 50:1	35'	2	4	10'	4	6	0.32	0.012	90
		3	72:1 81:1 100:1 130:1	144:1 200:1 225:1 256:1	50'	6	12	15'	6	12	0.3	0.011	85
		1	4:1 5:1	6:1	20'	0.7	1.4	6'	1.4	3	0.4	0.03	96
GPL 42	ZSS 41 ZSS 42 ZSS 43	2	14:1 16:1	20:1	35'	4	8	10'	8	12	0.42	0.024	90
		3	56:1 64:1 80:1 100:1	120:1 144:1 184:1	50'	12	24	15'	12	24	0.4	0.024	85
		1	4:1 4.5:1 5.2:1	6.25:1 8:1	20'	1.5	3	6'	3	6	1.2	0.06	96
GPL 52	ZSS 52 ZSS 56 ZSS 57	2	16:1 18:1 20.8:1 25:1 29:1	32:1 36:1 41.6:1 50:1:1	35'	10	20	10'	20	30	1.3	0.055	90
		3	72:1 81:1 100:1 130:1	144:1 200:1 225:1 256:1	50'	30	60	15'	30	60	1.35	0.05	85
		1	4:1 4.5:1 5.2:1	6.25:1 8:1	20'	1.5	3	6'	3	6	1.2	0.06	96

¹⁾ Valid for 21 °C ambient temperature

Stepper Motor with GPL Low-backlash Planetary Gear

ZSS Stepper Motor with GPL Gear

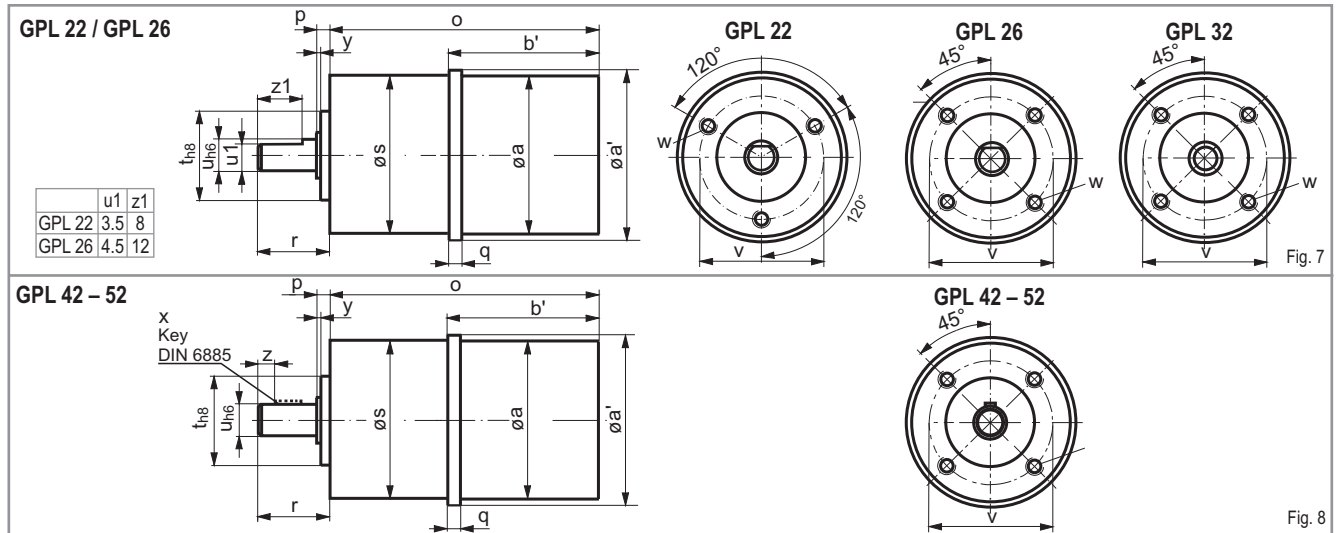

Dimensions

Gear	Stepper Motor	Dimensions in mm																
					1 stage	2 stages	3 stages											
		a	a'	b'	o			p	q	r	s	t	u	v	w	x	y	z
GPL 22	ZSS 19	19	22	29	50	57	64	2.5	4.5	15	22	12	4	16	M2.5x4	-	0.5	-
	ZSS 20	19	22	45.5	66.5	73.5	80.5											
	ZSS 25	25	25.5	33.5	54.5	61.5	68.5											
	ZSS 26	25	25.5	49.5	70.5	77.5	84.5											
GPL 26	ZSS 25	25	26	33.5	59	67	75	2.5	5	17	26	14	5	20	M3x4	-	0.5	-
	ZSS 26	25	26	49.5	75	83	91											
GPL 32	ZSS 32	32	33	40.5	69.5	78.5	87.5	4	5	20	32	20	6	26	M3x5	-	1	-
	ZSS 33	32	33	59.5	88.5	97.5	106.5											
GPL 42	ZSS 41	42	43	53	88	100.5	113	4	7	22.5	42	25	8	32	M4x8	3x3x14	1	2.25
	ZSS 42			68	103	115.5	128											
	ZSS 43			83	118	130.5	143											
52	ZSS 52	52	53	82.5	123.5	138	152.5	4	9	24	52	32	12	40	M5x8	4x4x16	1	2
	ZSS 56	56.4	57	73	114	128.5	143											
	ZSS 57	56.4	57	89	130	144.5	159											

Shock Factor for Cyclical Operation

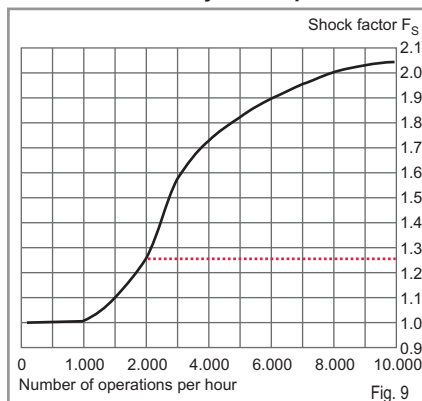

Weight / Permissible Loads / Protection Modes

Gear	Weight without motor			Permissible Radial load (center of shaft)	Permissible Axial load	Protection mode Gear	Protection mode Gear + motor
	1 stage	2 stages	3 stages				
	g						
GPL 22	50	75	100	30	24	IP 44	IP 40 IP 44
GPL 26	70	90	115	50	40	IP 44	IP 40 IP 44
GPL 32	135	180	250	80	65	IP 54	IP 40 IP 44
GPL 42	275	350	425	150	120	IP 54	IP 43 IP 65
GPL 52	475	600	725	250	200	IP 54	IP 43 IP 65

IP xx = Standard
IP xx = optional
(dimensions on request)

Electrical Connection

Type ZSS phytron stepper motors are 8-lead versions.

The motors can be used with unipolar or bipolar control mode, as the windings can be differently connected.

5-lead or 6-lead connection is applicable for the unipolar control mode.

In the bipolar control mode, 4-lead motor wiring is required, windings connected in parallel or in series.

The information in the ZSS motor connection leaflet (delivered with each motor) must be regarded when wiring the motor in order to provide for EMC compliant wiring. The motor connection leaflets are also available by download from the phytron homepage.

Stepper Motor ZSS with Free Wire Ends

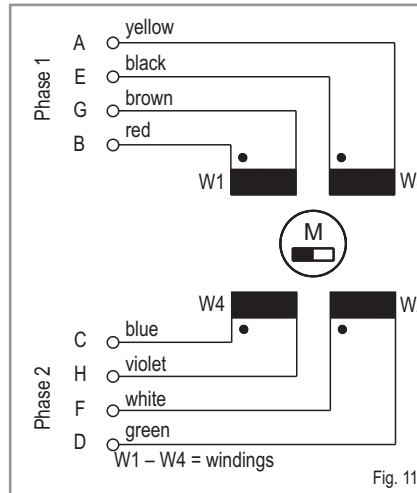

Connection Type 4-leads / parallel

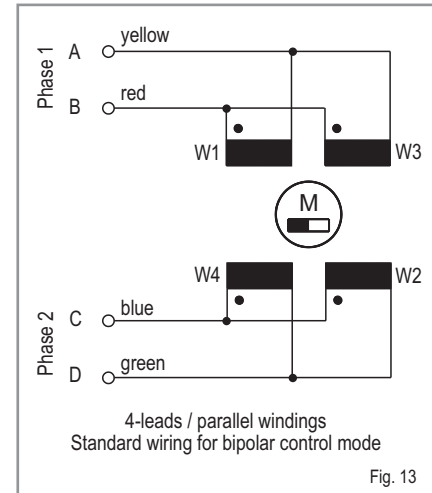

Connection Type 5-leads

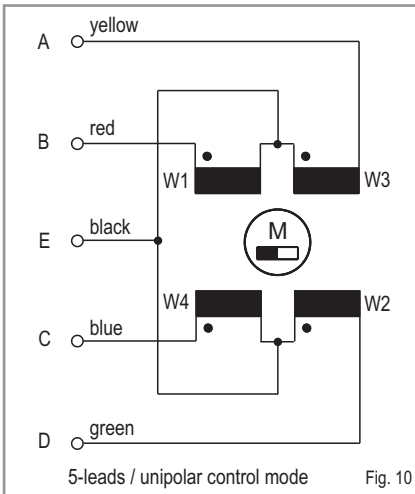

Connection Type 6-leads

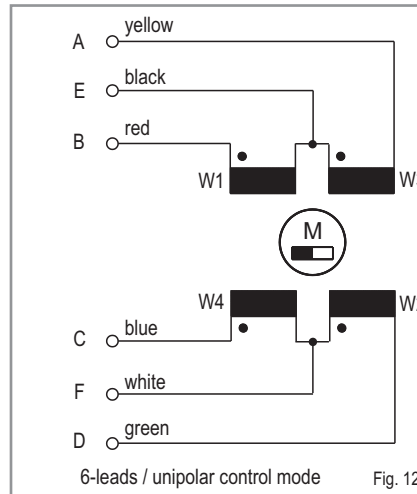

Connection Type 4-leads / serial

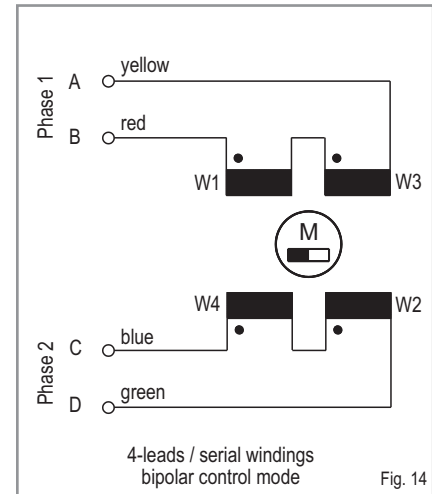

Phase Currents

For ZSS phytron stepper motors, the rated current [A] per motor phase is printed on the rating plate. The last digits of the motor's type number define the rated current.

Example: ZSS 32.201.1,2

The **rated current** is defined for full step operation, at bipolar control mode, with parallel connected motor windings.

According to the connection mode, the motor windings receive different currents. Therefore, for identical power dissipation in the motor, the allowable **phase current** is determined by the connection mode. For short time, double current overload is acceptable.

Control mode	Bipolar control mode Full step operation		Unipolar control mode Full step operation	
	4-leads parallel windings standard wiring for bipolar control mode	4-leads serial windings	5-leads	6-leads
Motor connection				
Allowable phase current for identical power dissipation	Rated current	Rated current x 0.5	Rated current x 0.707	Rated current x 0.707

Electrical Characteristics / Phase Currents / Resistance / Inductivity

Size	Type	Standard winding 1				Standard winding 2				Standard winding 3			
		Phase current		resistance per winding	Inductivity per winding ¹⁾	Phase current		resistance per winding	Inductivity per winding ¹⁾	Phase current		resistance per winding	Inductivity per winding ¹⁾
		unipolar operation	bipolar operation			unipolar operation	bipolar operation			unipolar operation	bipolar operation		
		A		Ω	mH	A		Ω	mH	A		Ω	mH
19	ZSS 19	0.21	0.3	14.5	2.2	0.42	0.6	3.7	0.55	0.84	1.2	1.25	0.15
	ZSS 20												
25	ZSS 25	0.21	0.3	24	6	0.42	0.6	6.5	1.5	0.84	1.2	1.9	0.4
	ZSS 26			43	12			11.7	3.2			3.4	1
32	ZSS 32	0.42	0.6	9.0	5.3	0.84	1.2	2.5	1.2	1.75	2.5	0.6	0.3
	ZSS 33			15	9.3			3.8	2.2			0.94	0.6
42	ZSS 41	0.42	0.6	10.2	7.6	0.84	1.2	2.7	2	1.75	2.5	0.55	0.4
	ZSS 41/1 ²⁾			10.2	7.6			2.7	2			0.55	0.4
	ZSS 42			14.5	11			3.4	3			0.68	0.7
	ZSS 42/1 ²⁾			14.5	11			3.4	3			0.68	0.7
	ZSS 43			19	22.9			5.2	5.2			1	1.2
	ZSS 43/1 ²⁾			19	22.9			5.2	5.2			1	1.2
52	ZSS 52 ²⁾	0.84	1.2	5.3	7	1.75	2.5	1.2	1.6				
56	ZSS 56 ²⁾	0.84	1.2	5.7	6.7	1.75	2.5	1.3	1.7				
	ZSS 57 ²⁾			7.8	7.8			1.6	2.4				

Remarks:

¹⁾The inductivity values apply for each single winding as well as for parallel connected windings.

In the bipolar mode, the windings can also be connected in series. In this case, the inductivity is multiplied by 4.

²⁾ZSS 41/1, 42/1, 43/1, 52, 56, 57 with earthing screw on the terminal board

Frequency Characteristics

The curves correspond to the limit values of the operational characteristics (M) as a function of the control pulses (frequency/speed), for two different supply voltages (U_b).

The motor connection type is 4-leads with parallel windings. The motors are controlled by phytron stepper motor power stages in the half-step mode.

Power Characteristics

For each frequency curve, the power characteristic (P) indicates the power delivered by the output shaft.

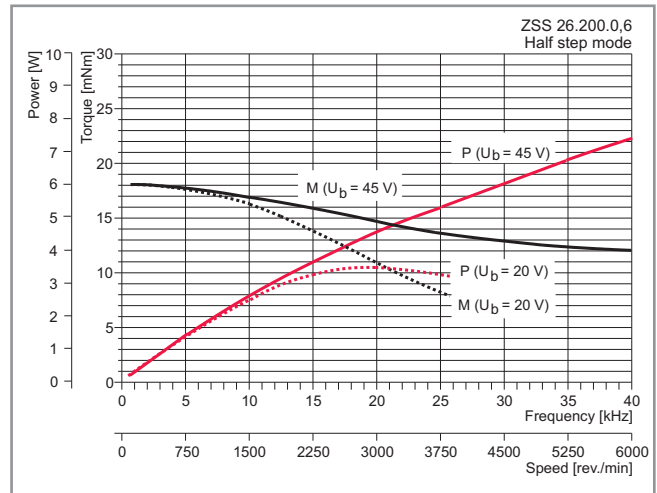

Fig. 17

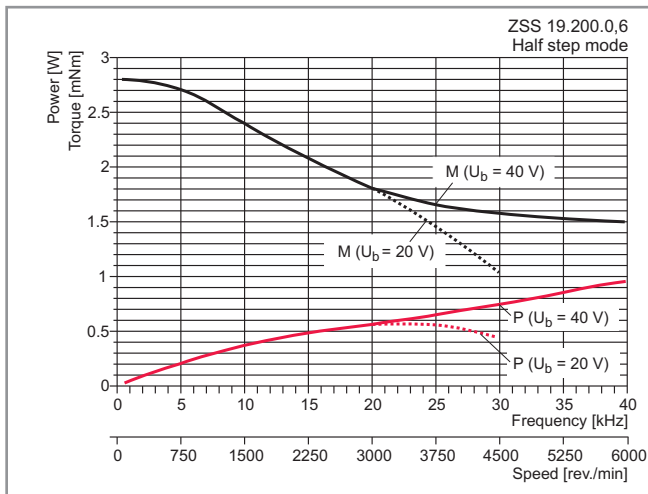

Fig. 15

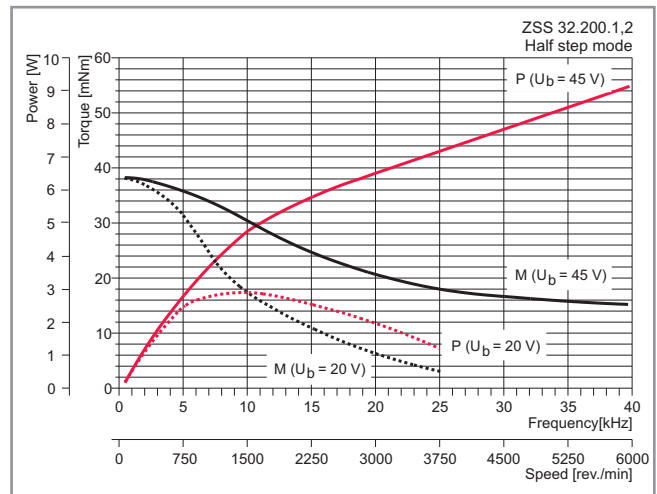

Fig. 18

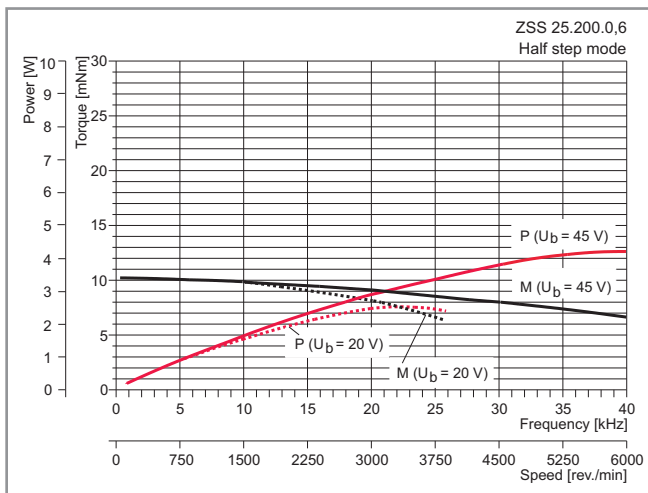

Fig. 16

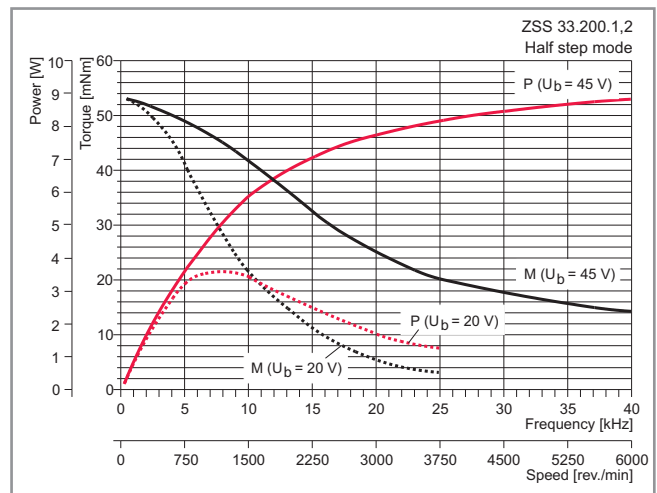

Fig. 19

Frequency Characteristics

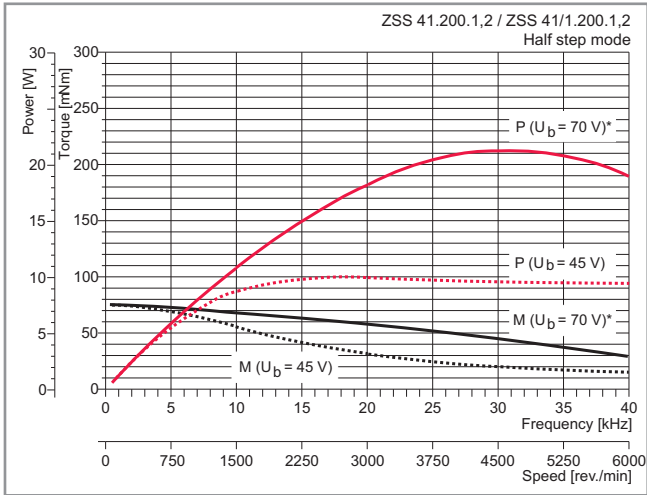

Fig. 20

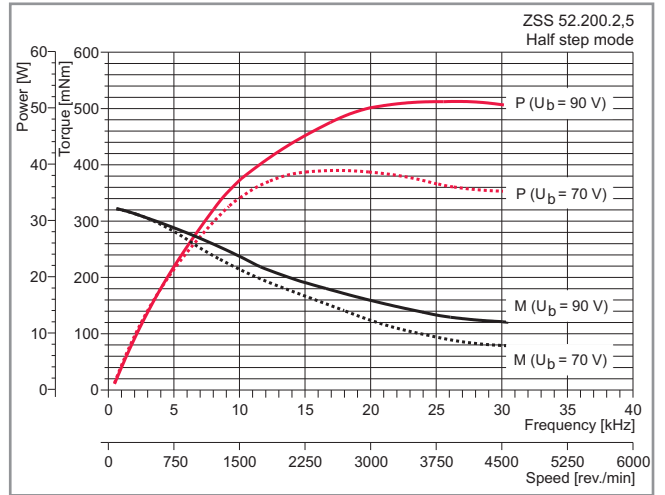

Fig. 23

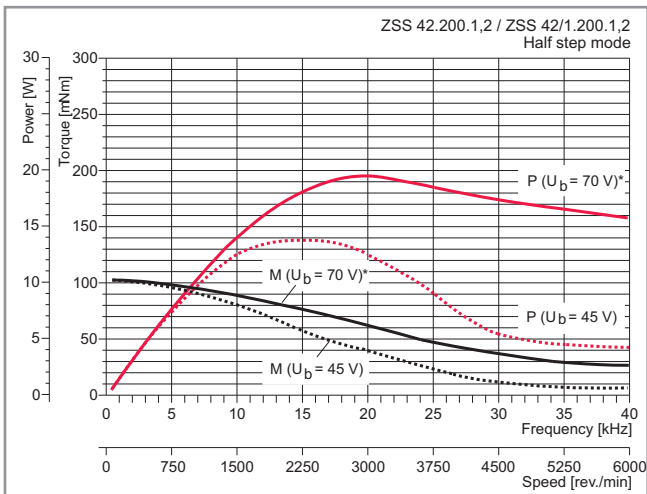

Fig. 21

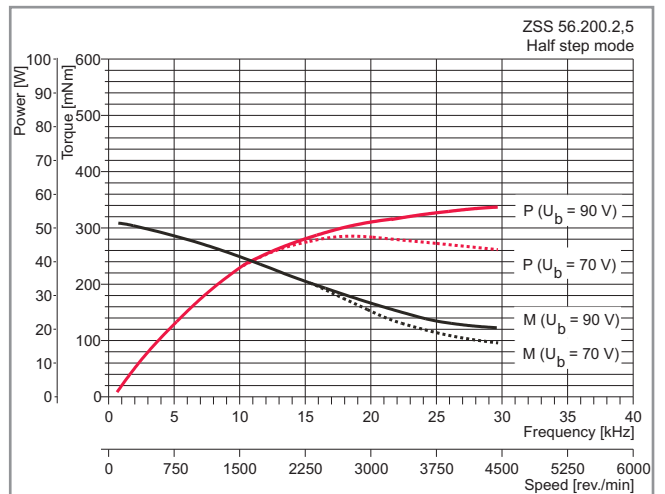

Fig. 24

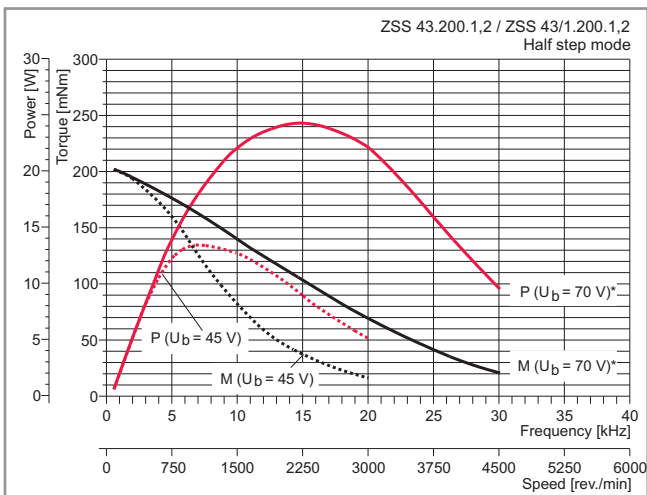

Fig. 22

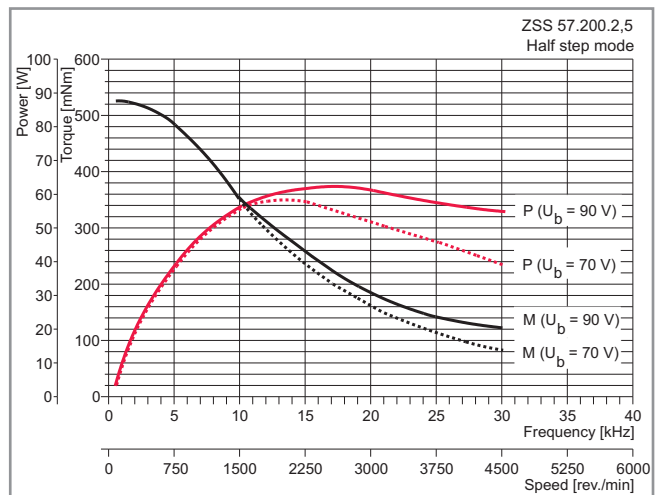

Fig. 25

* $U_b = 70 \text{ V}$ permissible for motors with earthing screw

Notes:
