

U3

Force Transducers



Special features

- Tensile / compressive force transducers
- Nominal forces 500 N ... 100 kN
- Integrated lateral force compensation
- Low overall height
- Flanged ends on both side
- Sturdy design through high dynamic load-carrying capacity
- Stainless steel housing

Dimensions (in mm; 1 mm= 0.03937 inches)

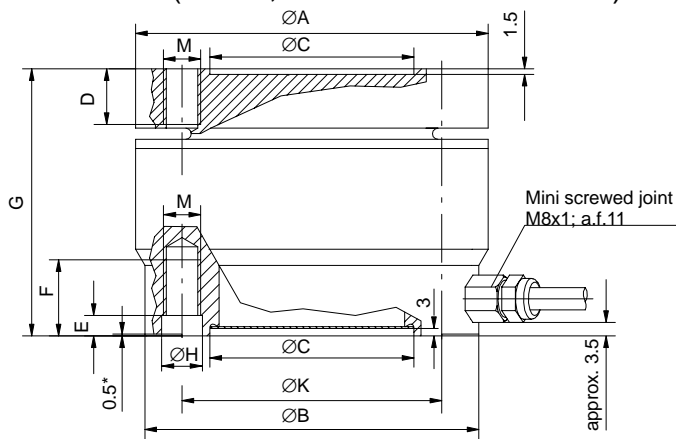

* only at 50 kN and 100 kN

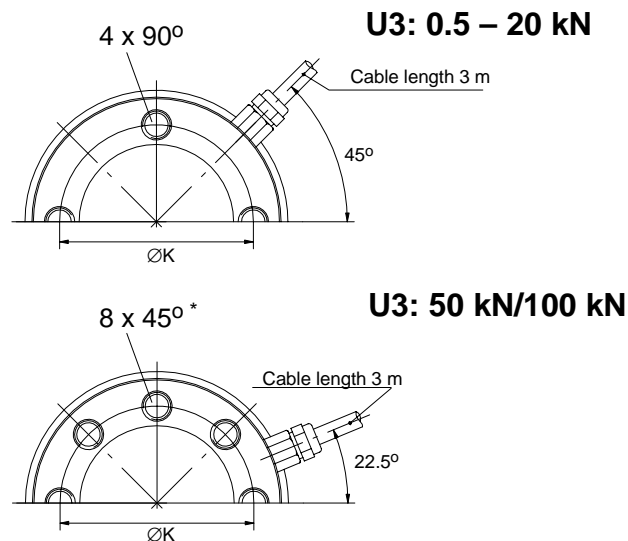

Nominal force	ØA	ØB _{-0.02}	ØCH ⁸	D	E	F	G	ØH	ØK ^{±0.1}	M
U3/0.5-10 kN	54	50	34	8.5	5	13	47	5.5	42	M5
U3/20 kN	95	90	55	15	5.5	20.5	72	11	70	M10
U3/50 kN										
U3/100 kN										

Specifications (VDI/VDE 2638)

Type			U3								
Nominal force	F _{nom}	kN	0.5	1	2	5	10	20	50	100	
Accuracy class			0.2								
Nominal sensitivity	C _{nom}	mV/V	2								
Rel. sensitivity deviation compressive force			< ±0.2								
Rel. tensile/compressive force sensitivity diff.	d _{zd}	%	<2	<1							
Relative zero signal deviation	d _{s,0}	%	<1								
Relative range of inversion (0.5 F _{nom} to F _{nom})	u _{0.5}	%	<0.2								
Linearity deviation compressive force	d _{lin}	%	<0.2								
Linearity deviation tensile force	d _{lin}	%	<0.3	<0.2							
Effect of temperature on sensitivity/10 K by reference to nominal sensitivity	TK _C	%	<0.2	<0.1							
Effect of temperature on zero signal/10 K by reference to nominal sensitivity	TK ₀	%	<0.1								
Effect of eccentricity at 1 mm	d _E	%	< ±0.1								
Effect of transverse forces transverse force 10 % F _{nom} ¹⁾	d _Q	%	< ±0.1							< ±0.2	
Relative creep over 30 min	d _{crF+E}	%	< ±0.1								
Input resistance	R _e	Ω	>345								
Output resistance	R _a	Ω	300 – 400								
Isolation resistance	R _{is}	Ω	>2x 10 ⁹								
Reference excitation voltage	U _{ref}	V	5								
Operating range of the excitation voltage	B _{U,GT}	V	0.5 to 12								
Nominal temperature range	B _{t,nom}	°C	–10 to +70								
Operating temperature range	B _{t,G}	°C	–30 to +85								
Storage temperature range	B _{t,S}	°C	–50 to +85								
Reference temperature	t _{ref}	°C	+23								
Maximum operating force	(F _G)	%	130	150					130		
Limit force	(F _L)	%	130	150					130		
Breaking force	(F _B)	%	>300							250	
Static lateral limit force ¹⁾	(F _Q)	%	100						80	50	
Permissible eccentricity	e _G	mm	25					40	32	20	
Nominal displacement	S _{nom}	mm	<0.08						<0.1		
Fundamental resonance frequency	F _G	kHz	1.3	2.1	3.1	5.2	7.1	3.7	5.7	7.25	
Relative permissible vibrational stress	F _{rb}	%	100	160							
Weight		kg	approx. 0.6					approx. 2.5			
Degree of protection to DIN EN60529			IP65								
Cable length, six-wire connection		m	3								

¹⁾ by reference to a force introduction point on the force-introduction surface

Accessories (to order):

'Complete adapter' for knuckle eye mounting

0.5–10 kN Order no. 2–9289.1956
 20 kN Order no. 2–9289.1957
 50 kN Order no. 2–9289.1958
 100 kN Order no. 2–9289.2280

Knuckle eye 1–ZGUW

0.5–10 kN Order no. 1–U2A/1t/ZGUW
 20 kN Order no. 1–U2A/2t/ZGUW
 50 kN Order no. 1–U2A/5t/ZGUW
 100 kN Order no. 1–Z4/100kN/ZGUW

Installation and accessories

Installation without Adapter

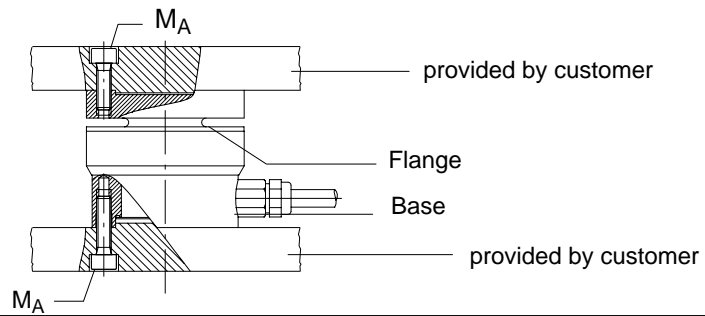

Nominal force (kN)	Starting torque M_A (Nm)	Thread
0.5 – 10	5	4 x M5
20	40	4 x M10
50	40	8 x M10
100	94	8 x M10–12.9 DIN912 galvanised

Installation with adapter and knuckle eye

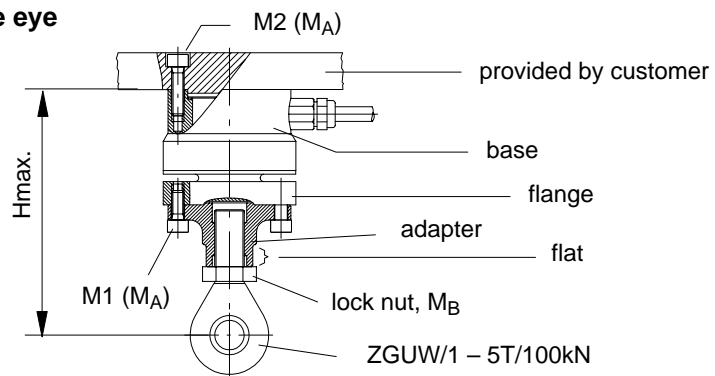

Nominal force (kN)	H_{Max} (mm)	Starting torque M_A (Nm)	Starting torque M_B (Nm)	Screws for adapter mounting	
				M1	M2
0.5 – 10	108	5	60	M5x12	M5
20	170	40	300	M10x25	M10
50	180	40	500	M10x25	M10
100	187	94	1000	M10x25	M10

Mounting accessories

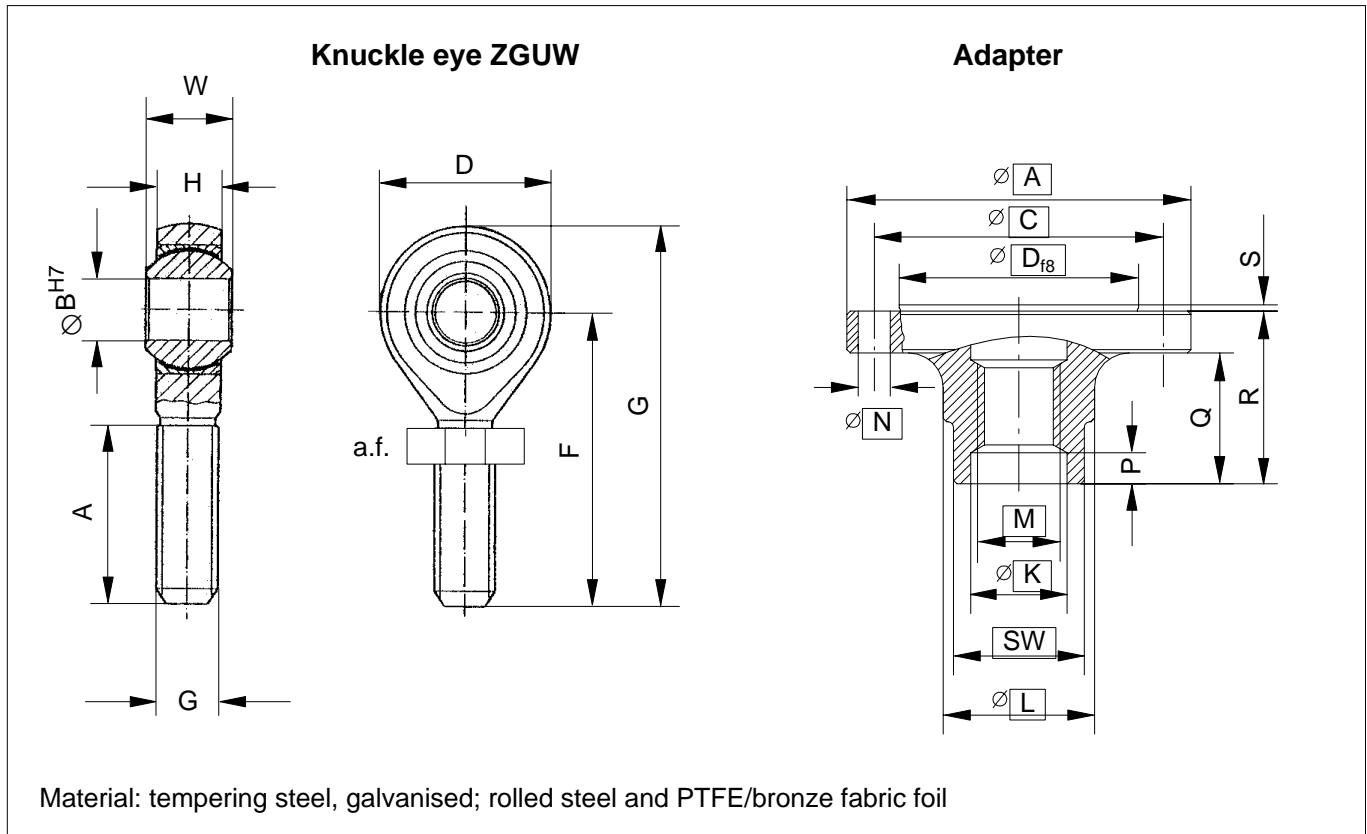

Knuckle eye

Nominal force (kN)	A	ØB ^{H7}	D	F	G	H	M	X	W	a.f.	Weight (kg)
0.5...10	33.5	12	32	54.5	70.5	12	M12	7	16	19	0.1
20	47	20	50	79.8	104.8	18	M20x1.5	9	25	30	0.4
50	57	25	60	94.5	124.5	22	M24x2	10	31	36	0.6
100	66	30 ^{H7}	70	110	145	25	M30x2	24	37	46	1.1

Adapter

Nominal force (kN)	ØA	ØC	ØD ^{f8}	M	ØK	ØL	ØN	P	Q	R	S	a.f.	Weight ¹⁾ (kg)
0.5...10	50	42	34	M12	14	22	4x5.5	4.5	19	25.1	0.9	19	0.15
20	90	70	55	M20x1.5	22	34	4x11	4.5	15	40.1	0.9	30	1.3
50	90	70	55	M24x2	26	42	8x11	6	20	45.1	0.9	36	1.45
100	90	70	55	M30x2	26	42	8x11	6	20	45.1	0.9	41	1.45

1) including screws

Modifications reserved.
All details describe our products in general form only. They are not to be understood as express warranty and do not constitute any liability whatsoever.

Hottinger Baldwin Messtechnik GmbH

Postfach 10 01 51, D-64201 Darmstadt
Im Tiefen See 45, D-64293 Darmstadt
Tel.: +49/61 51/ 8 03-0; Fax: +49/61 51/ 8039100
E-mail: support@hbm.com www.hbm.com



measurement with confidence